

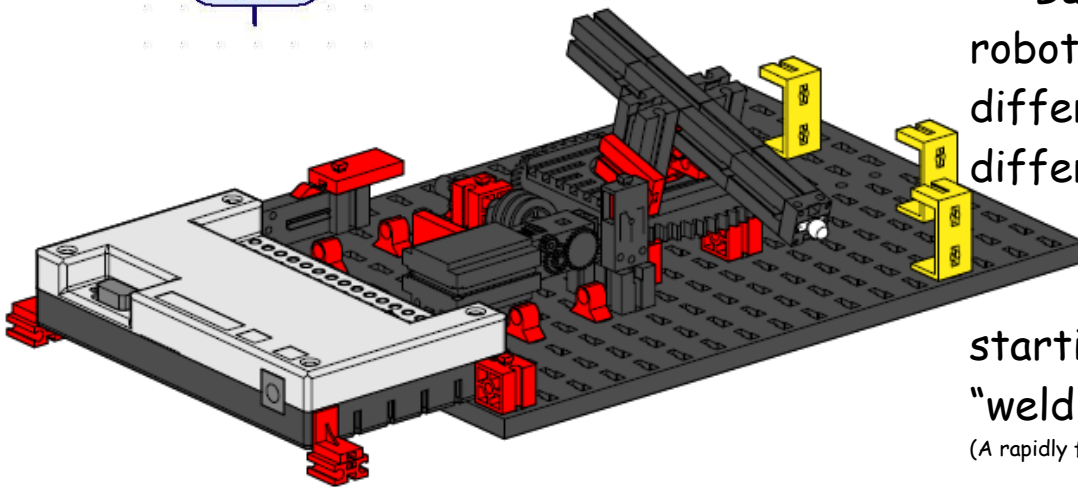

Model 8: The Welding Robot



Build and program a robot arm that will “weld” 3 different parts at 3 different locations.

The arm should return to the starting position after “welding” all 3 parts.

(A rapidly flashing lens tip lamp simulates the welding)

Assemble the model:

Step 1: Build the Welding Robot Model as shown in these assembly instructions.

Step 2: Wire three pushbutton switches to the **digital inputs I1 - I8** on the interface.

Step 3: Wire the lens tip lamp and 1 motor to the **outputs M1 - M4** on the interface.

Programming Tasks:

Task 1: The robot should begin when the program is started by going to the “home” position (if it is not already there). After a 2 second delay the robot will move to the first piece to be welded (first yellow block). The robot will “weld” the first piece by stopping and rapidly flashing its light several times. Then the robot will proceed to the next piece where it will stop and “weld” it and on to the third piece where it will stop and “weld”. The robot will then proceed to the home position and the program will start over and run until stopped manually (clicking STOP in the program).

Programming Tips: Use the pulse counter element on switch (I2) which will position the robot arm at exactly the right place for each of the yellow blocks (just experiment to find out how many pulses are needed for each position). Also, a counter element will help with the “welding” or flashing light.

A subprogram can be written for both the “welding” and for the return to home position (writing subprograms is an advanced programming technique).

Task 2 Modify the program to include an **EMERGENCY SHUTOFF SWITCH**. When the switch (I8) is pressed, the robot will shut down and the program will end. Note: some advanced programming techniques may be required.

Model 8 - The Welding Robot

Assembly Instructions Page 1

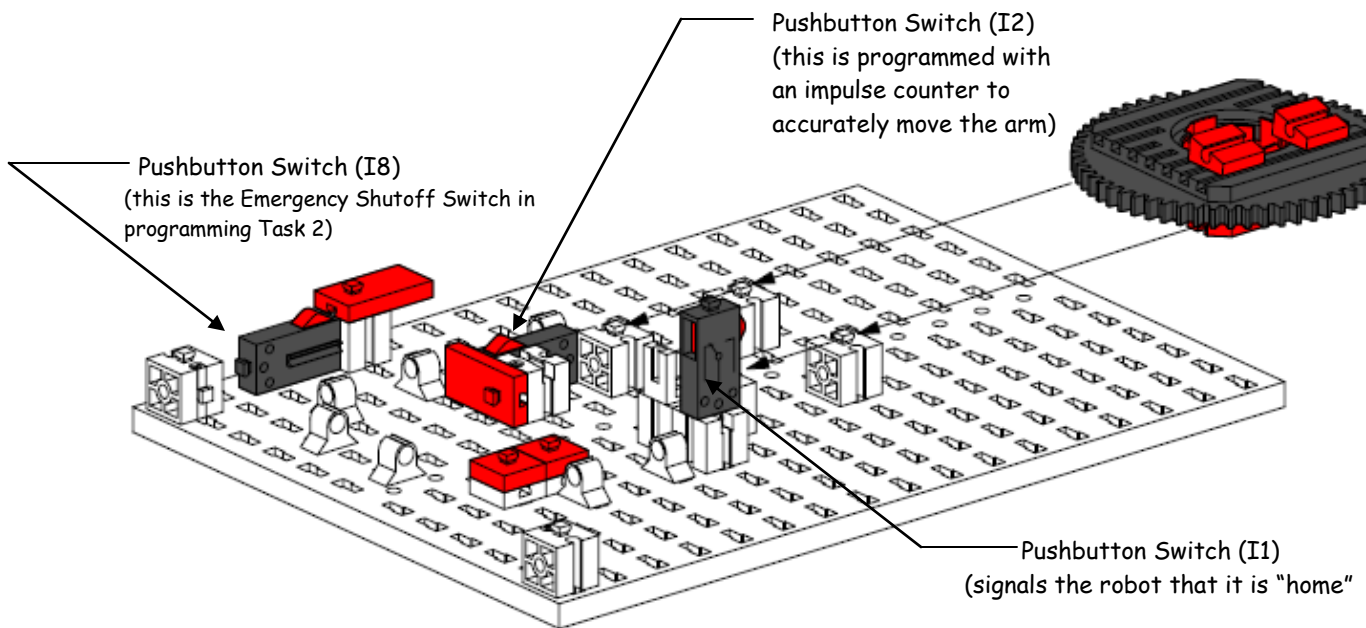
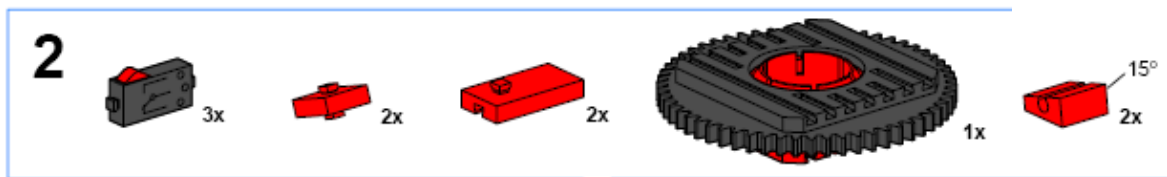
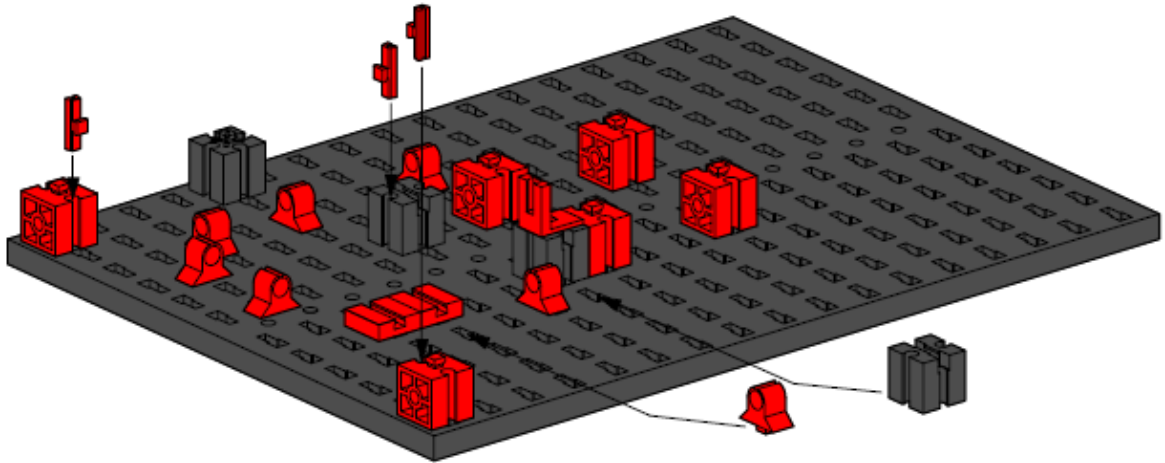
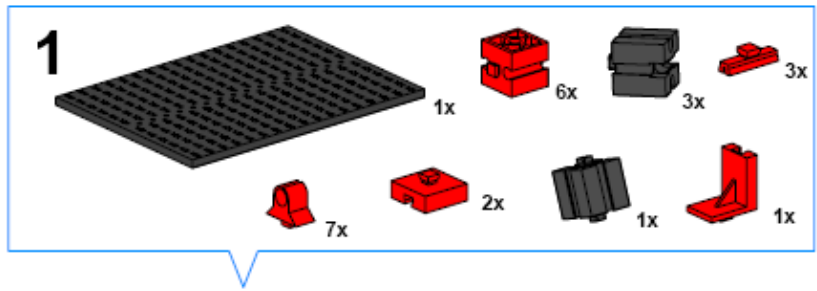

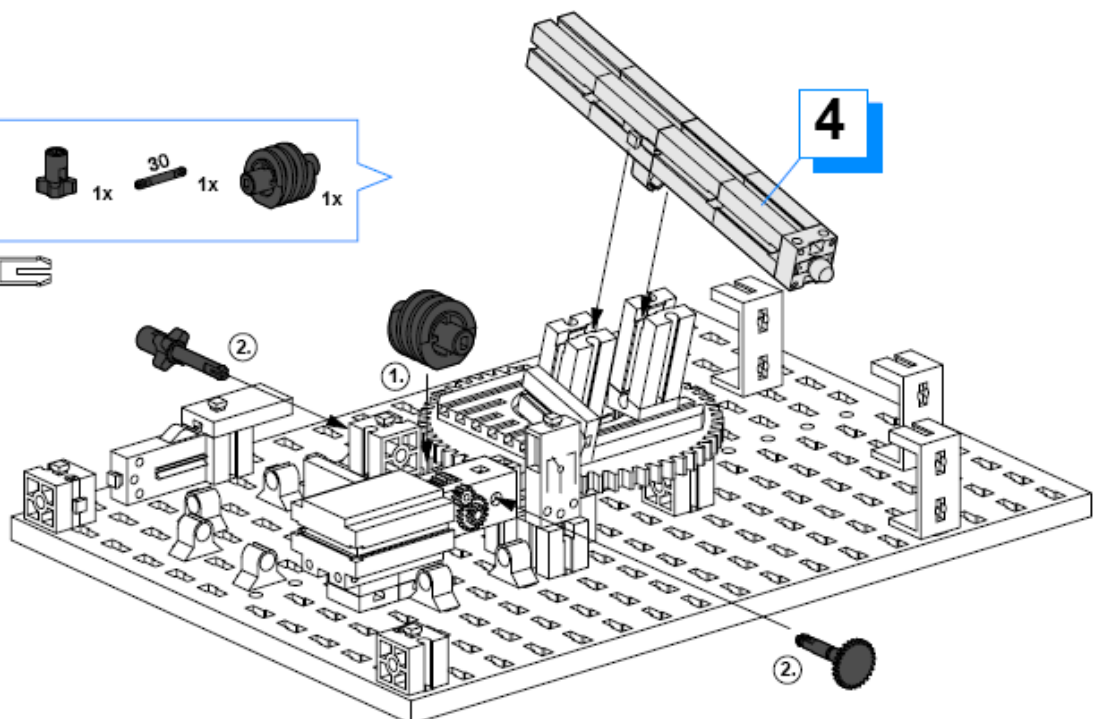
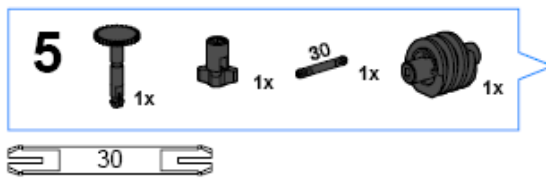
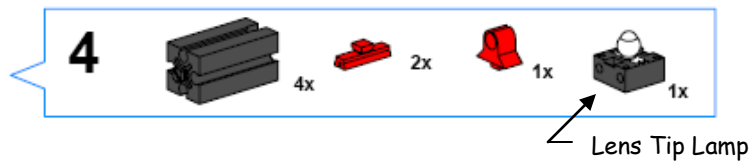
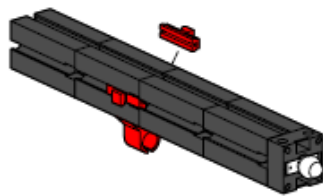
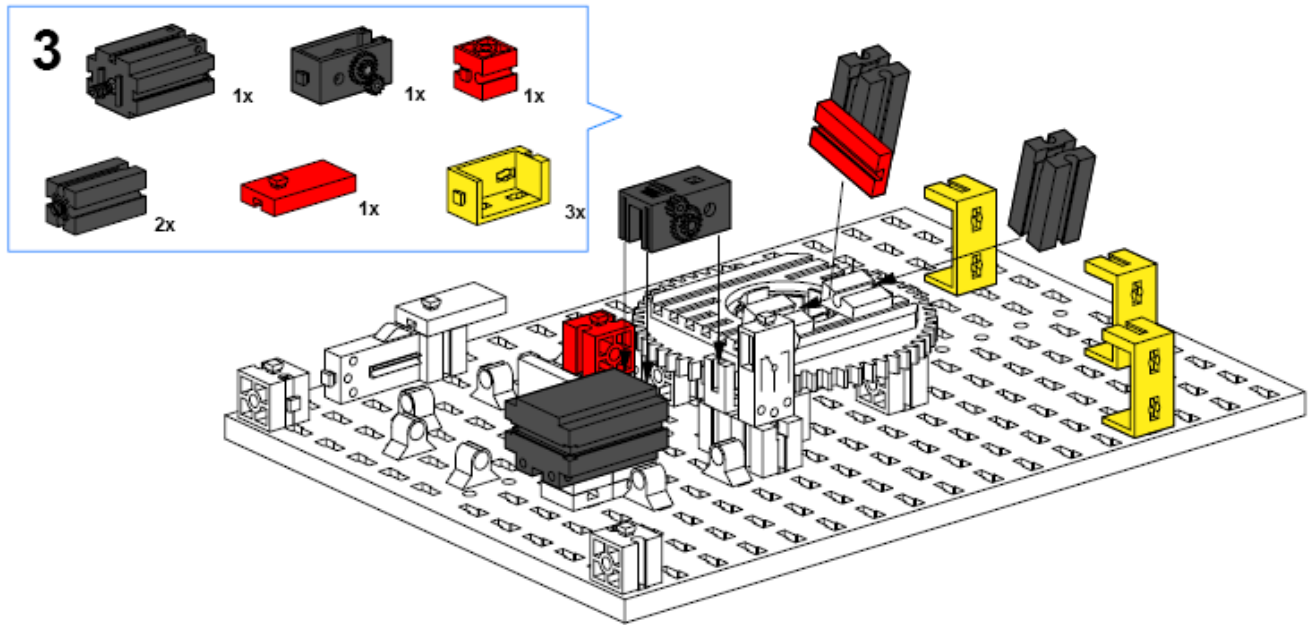

Assembly Instructions

Page 3

Model 8 - The Welding Robot

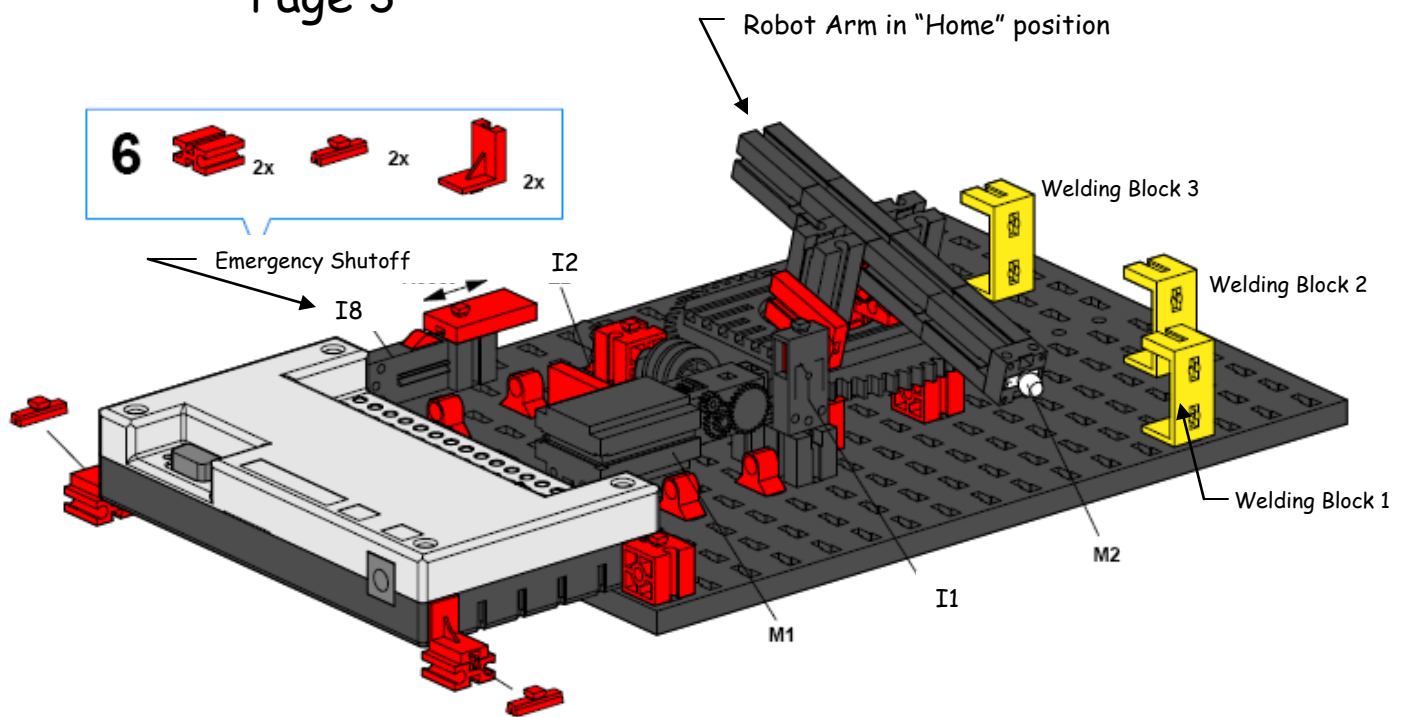

Wiring Diagram

Note: our interface looks a little different from this picture.

